



# BALL FOOT VALVE (VERTICAL TYPE)

TYPE:SOCKET JF100/ THREAD JF200



ISO 9001

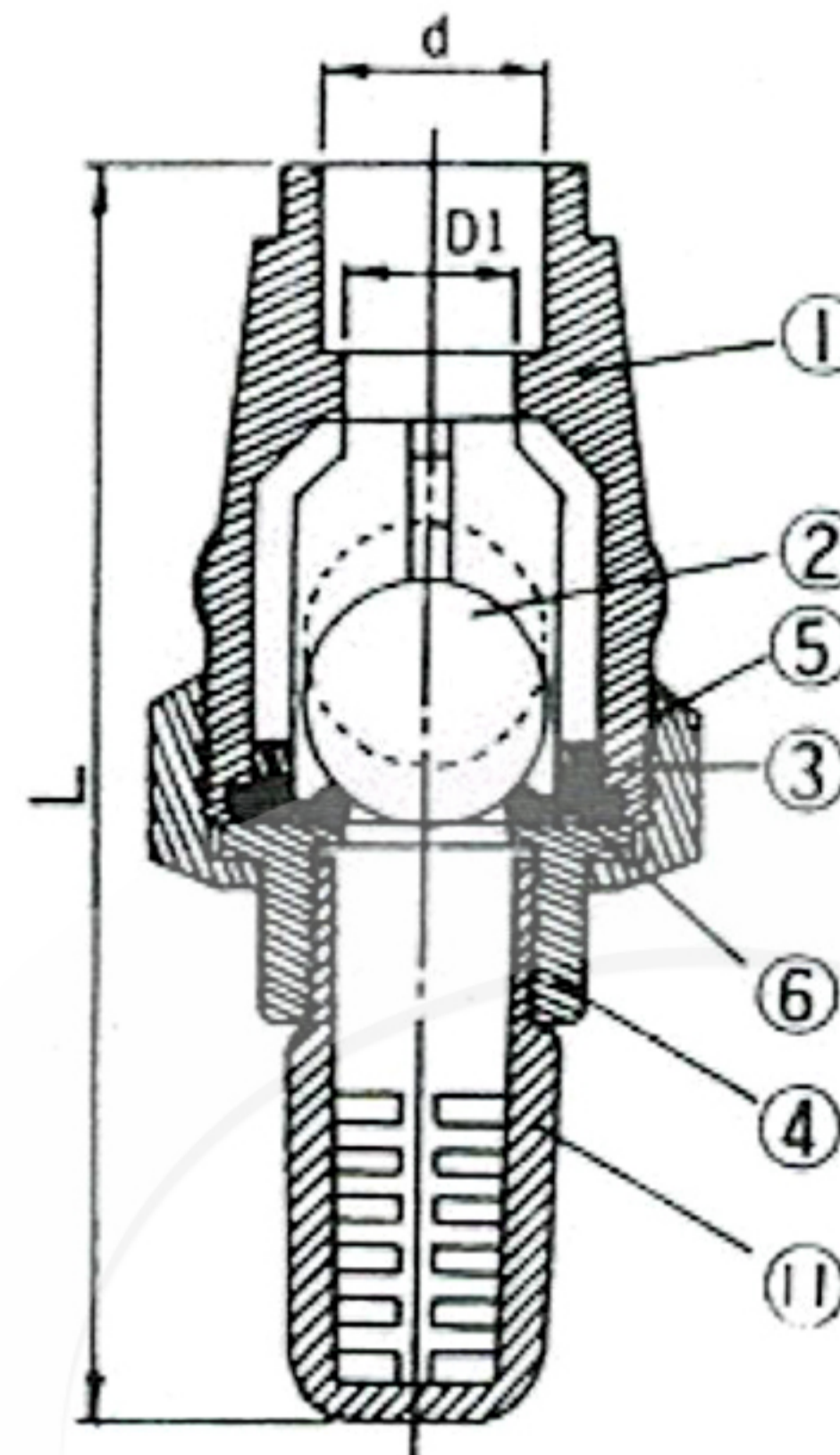

15A(1/2")~50A(2")

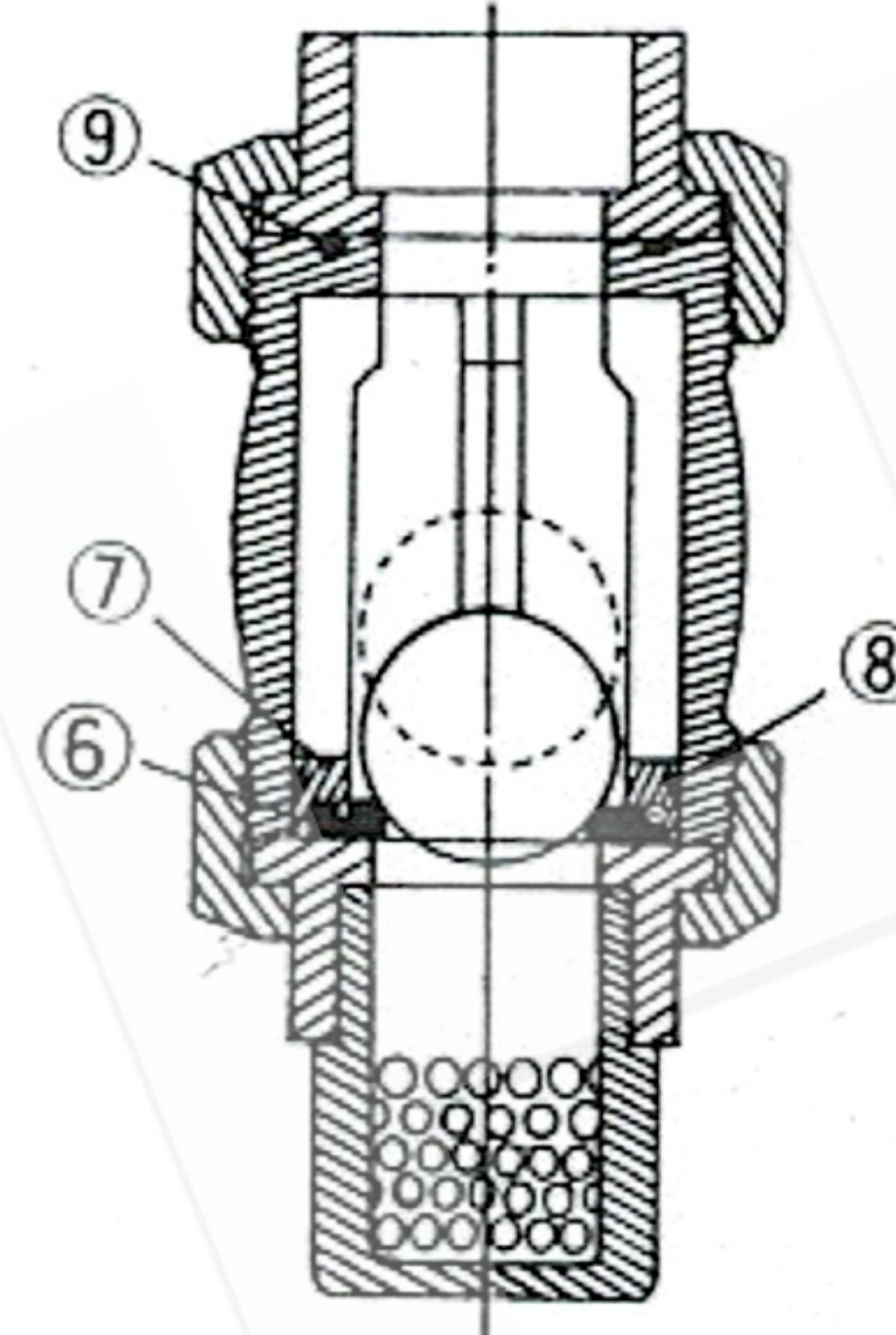

65A(2 1/2")~100A(4")

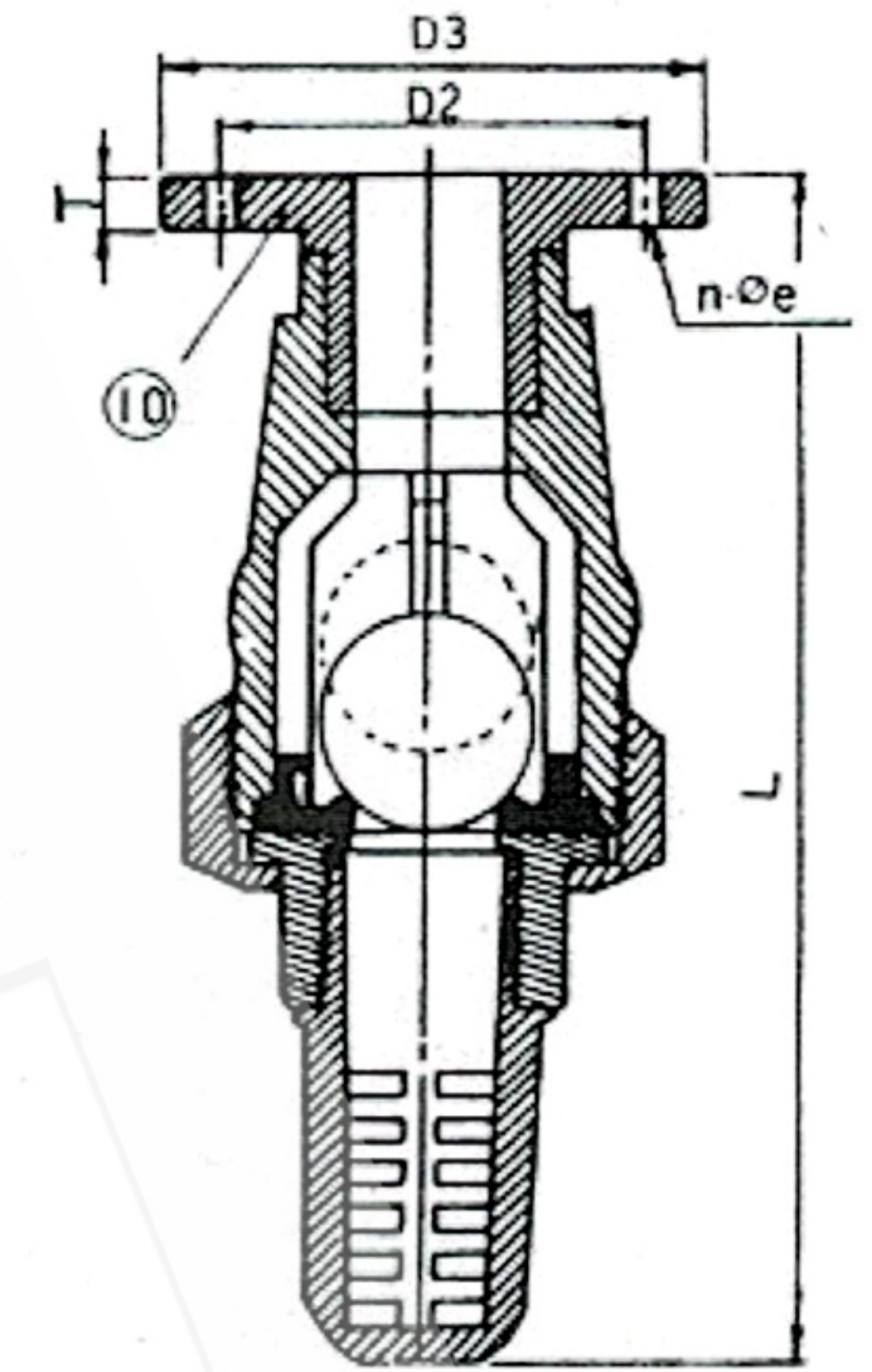

FLANGED TYPE  
15A(1/2")~250A(10")

## MATERIALS OF CONSTRUCTION

Item	Parts	Pcs	Materials	Item	Parts	Pcs	Materials
①	Body	1	UPVC, PP, CPVC, PVDF	⑦	Seat Carrier	1	UPVC, PP, CPVC, PVDF
②	Ball	1	UPVC, PP, CPVC, PVDF	⑧	Seat Carrier O'ring	1	EPDM, VITON
③	Washer	1/2	UPVC, PP, CPVC, PVDF	⑨	Solid End O'ring	1	EPDM, VITON
④	Connector	1/2	UPVC, PP, CPVC, PVDF	⑩	Flanged End	1	UPVC, PP, CPVC, PVDF
⑤	Union Nut	1/2	UPVC, PP, CPVC, PVDF	⑪	Screen	1	UPVC, PP, CPVC, PVDF
⑥	Seat	1	EPDM, VITON				

## DIMENSIONS TABLE

Standards Nom-Size DN-inch	JIS (m/m)										ANSI (inch)										DIN (m/m)												
	D1	d		D2	D3	n	Φe	L			T	D1	d		D2	D3	n	Φe	L			T	D1	d		D2	D3	n	Φe	L			T
		Screw	Socket					Screw	Socket	Flange			Screw	Socket					Flange	Screw	Socket			Flange	Screw					Socket	Flange		
15-1/2	15	PT	22	70	95	4	15	120	120	140	15	0.59	NPT	0.84	2.375	3.500	4	0.63	4.80	4.80	5.51	0.59	15	R1/2	20	65	95	4	14	120	120	140	15
20-3/4	20	PT	26	75	100	4	15	160	160	181	15	0.79	NPT	1.05	2.750	3.875	4	0.63	6.30	6.30	7.13	0.59	20	R3/4	25	75	105	4	14	160	160	181	15
25-1	26	PT	32	90	125	4	19	205	205	228	17	1.02	NPT	1.315	3.125	4.250	4	0.63	8.07	8.07	8.97	0.67	26	R1	32	85	115	4	14	205	205	228	17
32-1/4	36	PT	38	100	135	4	19	236	236	259	17	1.42	NPT	1.66	3.500	4.625	4	0.63	9.29	9.29	10.19	0.67	36	R1/4	40	100	140	4	18	236	236	259	17
40-1/2	36	PT	48	105	145	4	19	253	253	276	17	1.42	NPT	1.90	3.875	5.000	4	0.63	9.96	9.96	10.86	0.67	36	R1 1/2	50	100	150	4	18	253	253	276	17
50-2	40	PT	60	120	155	4	19	281	281	308	20	1.58	NPT	2.375	4.750	6.000	4	0.75	11.06	11.06	12.13	0.78	40	R2	63	125	165	4	18	281	281	308	20
65-2 1/2	65	PT	76	140	175	4	19	298	298	325	20	2.56	NPT	2.875	5.500	7.000	4	0.75	11.73	11.73	12.80	0.78	65	R2 1/2	75	145	185	4	18	298	298	325	20
80-3	80	PT	89	150	185	8	19	356	356	387	20	3.15	NPT	3.50	6.000	7.500	4	0.75	14.13	14.13	15.24	0.78	80	R3	90	160	200	8	18	359	359	387	20
100-4	100	PT	114	175	210	8	19	479	479	507	20	3.94	NPT	4.50	7.500	9.000	8	0.75	18.86	18.86	19.96	0.78	100	R4	110	180	220	8	18	479	479	507	20
125-5	125			210	250	8	23							8.500	10.000	8	0.88					125			210	250	8	18					
150-6	150			240	280	8	23				22			9.500	11.000	8	0.88			0.87		150			240	285	8	23				22	
200-8	200			290	330	12	23							11.750	13.500	8	0.88					200			295	340	8	23					
250-10	250			355	400	12	25				24			14.250	16.000	12	1.00			0.94		250			350	395	12	23				24	

\*.....Standard dimensions based on PVC material.